

COLORADO PARKS & WILDLIFE

# Boat Compendium for Aquatic Nuisance Species (ANS) Inspectors



COLORADO PARKS & WILDLIFE • 6060 Broadway • Denver, CO 80216  
(303) 291-7295 • (303) 297-1192 • [www.parks.state.co.us](http://www.parks.state.co.us) • [www.wildlife.state.co.us](http://www.wildlife.state.co.us)



## **STOP AQUATIC HITCHHIKERS!™**

The **purpose** of this compendium is to provide guidance to certified boat inspectors and decontaminators on various watercraft often used for recreational boating in Colorado. This book is not inclusive of all boats that inspectors may encounter, but provides detailed information for the majority of watercraft brands and different boat types. Included are the make and models along with the general anatomy of the watercraft, to ensure a successful inspection and/or decontamination to prevent the spread of harmful aquatic nuisance species (ANS).

***Note:***

We do not endorse any products or brands  
pictured or mentioned in this manual.

**Cover Photo Contest Winner:**

Cindi Frank, Colorado Parks and Wildlife Crew Leader  
Granby Reservoir, Shadow Mountain Reservoir and Grand Lake

**Cover Photo Contest 2nd Place Winner (Photo on Back Cover):**

Douglas McMillin, BDM Photography  
Aspen Yacht Club at Ruedi Reservoir

# Table of Contents

Boat Terminology .....	2
Marine Propulsion Systems .....	6
Alumacraft .....	10
Bayliner .....	12
Chris-Craft .....	15
Fisher .....	16
Four Winns .....	17
Glastron .....	18
Grenada Ballast Tank Sailboats .....	19
Hobie Cat .....	20
Jetcraft .....	21
Kenner .....	22
Lund .....	23
MacGregor Sailboats .....	26
Malibu .....	27
MasterCraft .....	28
Maxum .....	30
Pontoon .....	32
Personal Watercraft (PWC) .....	34
Ranger .....	35
Tracker .....	36
Trophy Sportfishing .....	37
Wakeboard Ballast Tanks and Bags .....	39
Acknowledgements .....	Inside back cover

# Boat Terminology

**aft**—In naval terminology, means towards the stern (rear) of the boat.

**anchor storage**—An interior compartment area on the boat, typically in the bow of the boat, where the anchor is stored.

**bait well**—An interior compartment that specifically holds live aquatic bait. Sometimes it is a separate container on the boat or incorporated in the live well compartment. May also be a pull out bucket in a live well.

**ballast tank**—A compartment within a boat, ship or other floating structure that holds water. Adding water (ballast) to a vessel lowers its center of gravity, and increases the draft of the vessel. A ballast tank can be filled or emptied in order to adjust the amount of ballast force. Small sailboats designed to be lightweight for being pulled behind automobiles on trailers are often designed with ballast tanks that can be emptied when the boat is removed from the lake or reservoir.

**bilge**—The lowest compartment on a boat where the two sides meet at the keel. The word is sometimes also used to describe the water that collects in this compartment. Water that does not drain off the side of the deck drains down through the boat into the bilge.

**bilge plug**—A plug located either on the transom wall or on the bottom of the hull that keeps lake water from entering the boat. It is removed when exiting the water body to help drain any water that has accumulated during the time on the lake or reservoir.

**bilge pump**—A water pump used to remove excessive bilge water. The water that collects in the bilge must be pumped out to prevent the bilge from becoming too full and threatening to sink the boat on the lake or reservoir.

**bow**—A nautical term that refers to the forward part of the hull of a boat.

**cavitation plate**—A flat metal fitting mounted horizontally above the propeller of an outboard motor, which helps direct the flow of water into the propeller and reduces cavitation. Cavitation is the effect caused when air is drawn down into the water by a propeller, resulting in loss of power, overspending of the engine and propeller, and pitting of the metal surfaces of the propeller.

**centerboard**—A retractable keel which pivots out of a slot in the hull of a sailboat, known as a centerboard trunk. A centerboard is used to provide lift to counter the lateral force from the sails.

**complex boat**—A boat that has one or more interior compartments **or** a closed hull **or** more than one motor.

**daggerboard**—A retractable keel used by various sailing craft. While other types of centerboard may pivot to retract, a daggerboard slides in a casing. The shape of the daggerboard converts the forward motion into a windward lift, countering the leeward push of the sail.

**fish box**—An interior compartment in a boat where fish are kept.

**gimbal**—A pivoted support that allows the rotation (up and down and side to side movement) of the outdrive of an I/O engine and outboard motor.

**hull**—The body or frame of a boat.

**inboard engine**—A marine propulsion system enclosed within the hull of the boat.

**inboard/outboard engine**—(I/O) is located inboard just forward of the transom (stern) and provides power to the drive unit located outside the hull.

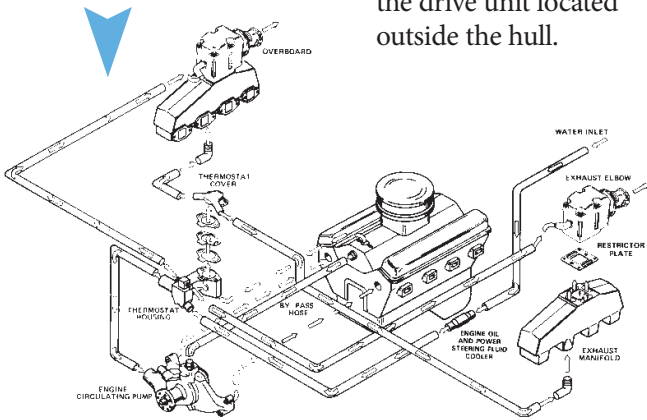
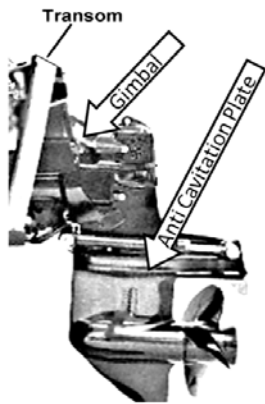

DIAGRAM © WWW.BOATPARTSTORE.COM



This drive unit (or lower unit or outdrive) resembles the bottom half of an outboard motor.

DIAGRAM © WEN BALDWIN, PSMFC ANS TRAINING CONTRACTOR

**jet boat**—A boat propelled by a jet of water ejected from the back of the craft. A jet boat draws the water from under the boat into a pump inside the boat, and then expels it through a nozzle at the stern.

**keel**—Runs in the middle of the boat, from the bow to the stern, and serves as the foundation or spine of the structure, providing the major source of structural strength of the hull. Keels are different from centerboards and other types of foils in that keels are made of heavy materials to provide ballast to stabilize the boat. Keels may be fixed, or non-movable or they may retract to allow sailing in shallow waters.

**live well**—An interior compartment found on many fishing boats that is used to keep caught fish alive. It works by pumping fresh water from the water body into the tank, as well as keeping the water aerated.

**live well pump**—A pump that assists in filling a live well with lake water.

**lower unit**—The bottom portion of an outboard motor or an inboard/outboard engine. The water found in this portion is lake water that has not been heated by the motor/engine.

**macerator pumps**—Pumps designed to empty holding tanks when fitted onto the plumbing in boats. The function of the pump is to suction the solids and liquids from the lines connected to the holding tanks and grind the effluent with the rotating cutter head down to a small particle size and discharge the waste.

**outboard motor**—A propulsion system for boats, consisting of a self-contained unit that includes engine, gearbox and propeller, designed to be affixed to the outside of the transom and is the most common motorized method of propelling small watercraft. As well as providing propulsion, outboards provide steering control, as they are designed to pivot over the gimbal (mounting bracket) and control the direction of the thrust. The skeg also acts as a rudder when the engine is not running.

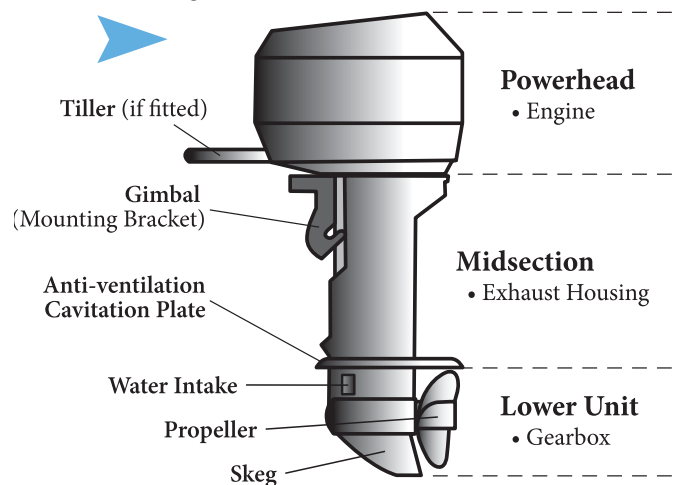

DIAGRAM © STATE OF COLORADO IDS DESIGN

**pitot tube**—A pressure measurement instrument used to measure the velocity of a boat at a given point. The pitot tube is usually attached to the transom.

**port**—A nautical term that refers to the left side of the boat as perceived by a person who is in the boat facing the bow.

**PWC**—Personal Water Craft: A recreational watercraft that the user sits or stands on, rather than inside of, as in a boat. Models have an inboard engine driving a jet pump that has a screw-shaped impeller to create thrust for propulsion and steering.



PHOTO © FLORIDA MARINE GUIDE

**simple boat**—A boat with an open hull, no containers or compartments and a single outboard motor.



**rudder**—A device used to steer a boat when moving through water. A rudder operates by redirecting water that has passed the hull, imparting a turning motion to the craft.

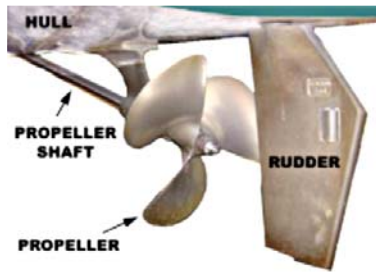

DIAGRAM © BOATCOURSE.COM

**sailboat**—A boat propelled partially or wholly by sail (See the diagram).

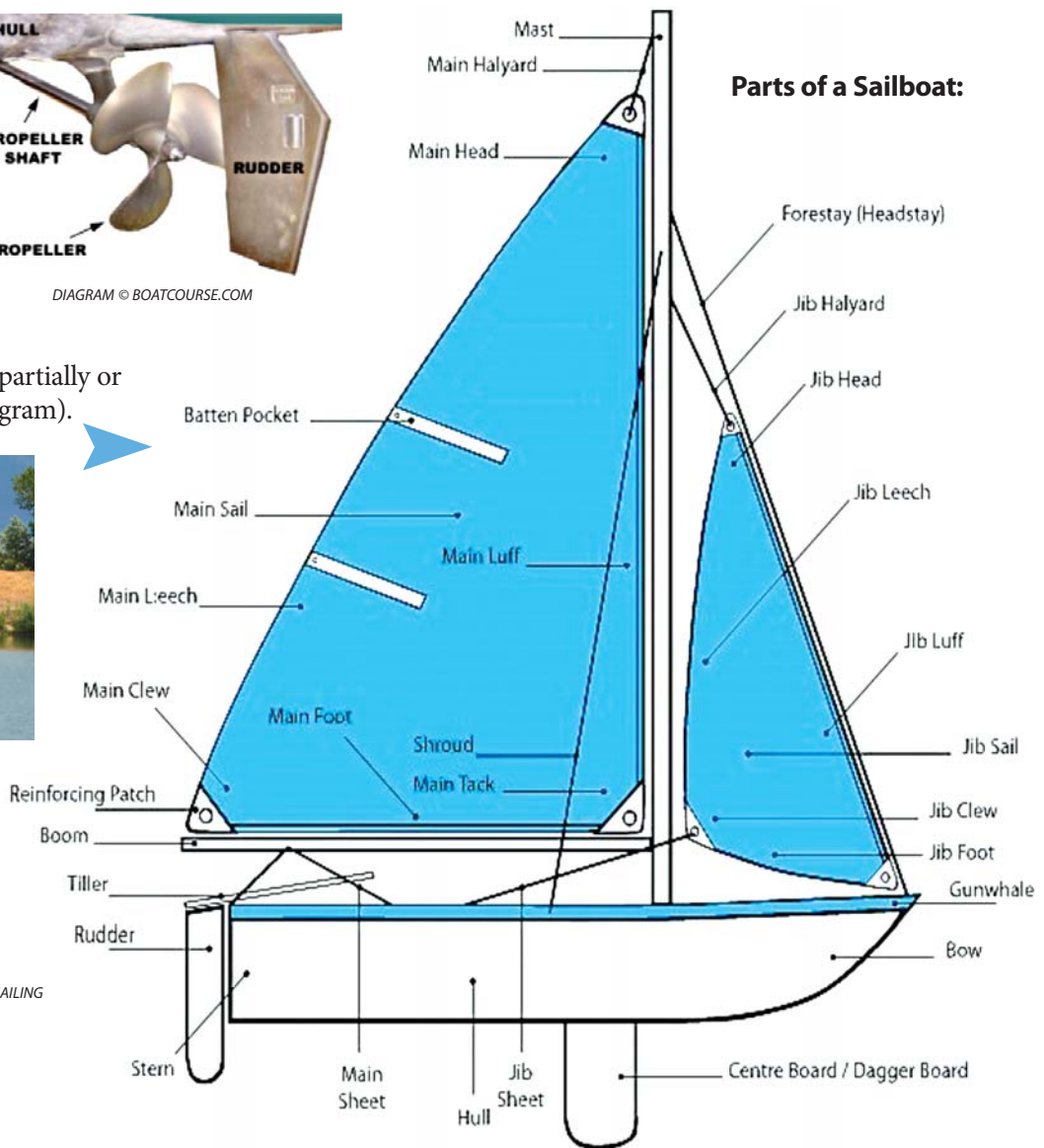

DIAGRAM © KNOT-A-LOT SAILING

**skag**—A support at the bottom of a rudder.

**starboard**—A nautical term that refers to the right side of the boat as perceived by a person who is in the boat facing the bow.

**stern**—The rear or aft-most part of a boat.

**transducer**—An instrument that projects a sound wave into the water. When the wave strikes something such as a fish, it is reflected back and displays size, composition, and shape of the object on a screen inside the boat.

**transom well**—A recessed area where water collects that is formed by the transom. Good examples of this are the stern of a pontoon boat or the area where an outboard motor is attached.

**trim tabs**—The small surfaces (shelves) that are connected to the transom on a boat. Trim tabs are mostly found on cruisers, sport fishing boats and center console boats ranging from 20 feet and up.



**transom**—The surface that forms the flat back panel of the stern of a boat.

For example:  
the outboard motor  
attaches to the transom  
with either clamps or  
bolts.

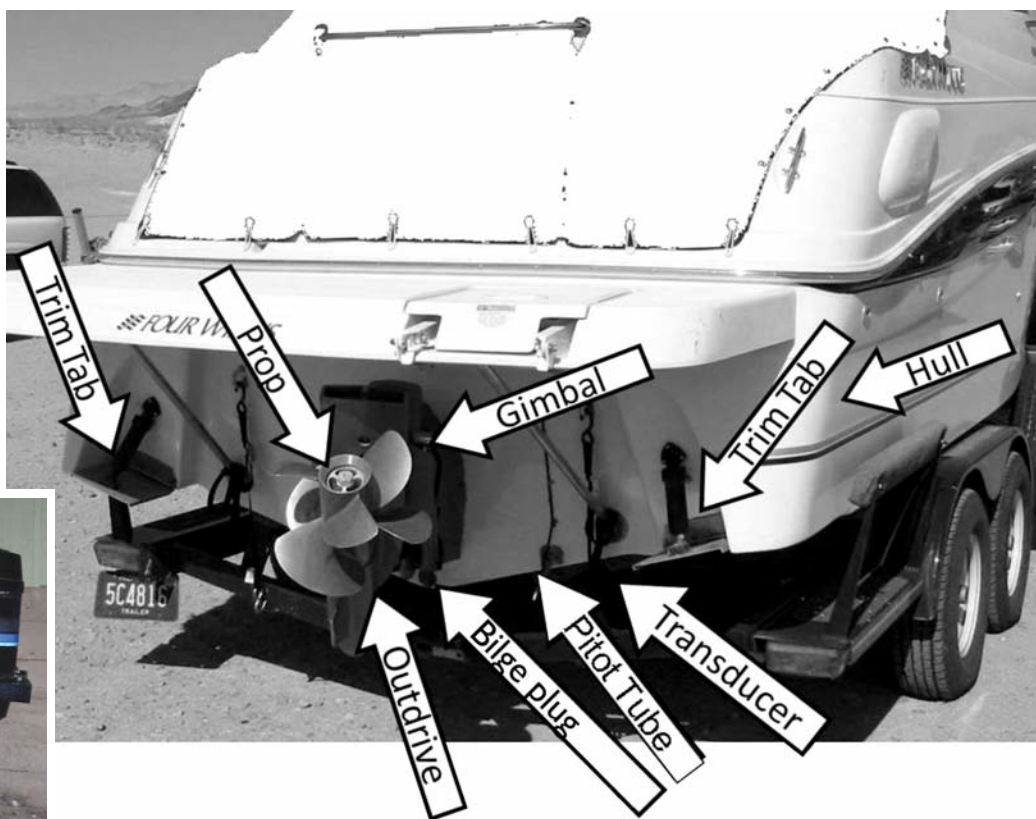

PHOTO © WIKIPEDIA

DIAGRAM © WEN BALDWIN, PSMFC ANS TRAINING CONTRACTOR

# Marine Propulsion Systems

The purpose of this section is to inform the boat inspector about the propulsion systems that are used to power watercraft. There are: electric and gas trolling motors, outboard motors, inboard/outboard engines (I/O), inboard engines, and jet drives for jet boats and PWCs (See pages 21 and 34).

## Trolling Motors

An **electric trolling motor** is a marine propulsion system consisting of a self-contained unit that includes an electric motor, propeller and controls, and is affixed to an angler's boat, either at the bow or stern.

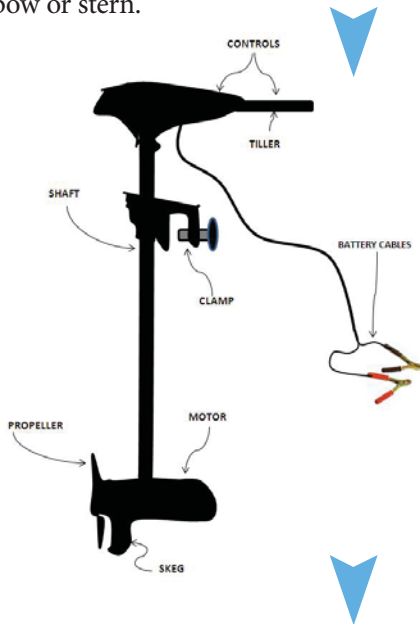

PHOTO © WIKIPEDIA

A **gasoline-powered outboard**, if it is not the vessel's primary source of propulsion, may also be referred to as a **gasoline trolling motor**. Small outboard motors are frequently used as trolling motors on boats with much larger engines that do not operate as efficiently or quietly at trolling speeds. These typically are designed with a manual pull start system, throttle and gearshift controls mounted on the body of the motor, and a tiller for steering. Trolling motors are often lifted from the water to reduce drag when the boat's primary engine is in operation.





As shown in the first photo, the intakes on some of the gas trolling motors are underneath the cavitation plate. Others are so close to the edge that most mufflers do not cover them in order to perform a decontamination, as shown in the second photo.



**Outboard Motors**

An **outboard motor** is a marine propulsion system for boats, consisting of a self-contained unit that includes engine, gearbox, and propeller, designed to be affixed to the outside of the transom and is the most common motorized method of propelling small watercraft. As well as providing propulsion, outboards provide steering control, as they are designed to pivot over the gimbal (mounting bracket) and control the direction of the thrust. The skeg also acts as a rudder when the engine is not running.

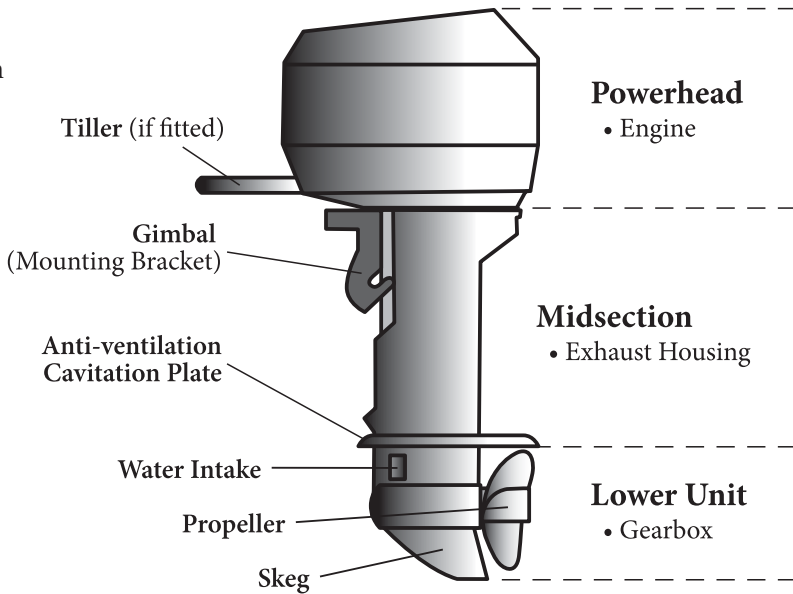

The intakes on this Evinrude outboard motor are only on one side and are shown as the small rectangle.



This photo shows an outboard motor on a pontoon boat with a back up gas trolling motor.



**Inboard/Outboard Engines**

An **inboard/outboard (I/O) engine** is located inboard just forward of the transom (stern) and provides power to the drive unit located outside the hull. This drive unit (or lower unit or outdrive) resembles the bottom half of an outboard motor.

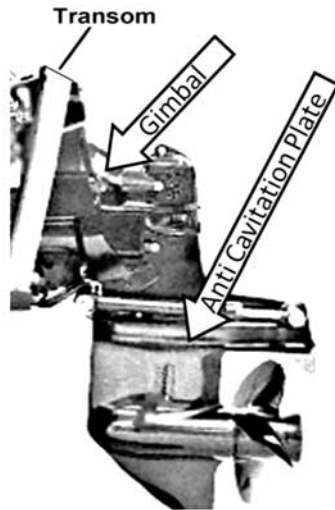

DIAGRAM © WEN BALDWIN, PSMFC ANS TRAINING CONTRACTOR

The following diagram demonstrates that after an I/O has exited the lake or reservoir there is water in the hose from the water inlet to the engine circulating pump. When the engine is started in another water body, this water goes through the “cold” engine and is expelled into the water. If this water is from a positive reservoir the chance of live veligers being present in the water is very high.

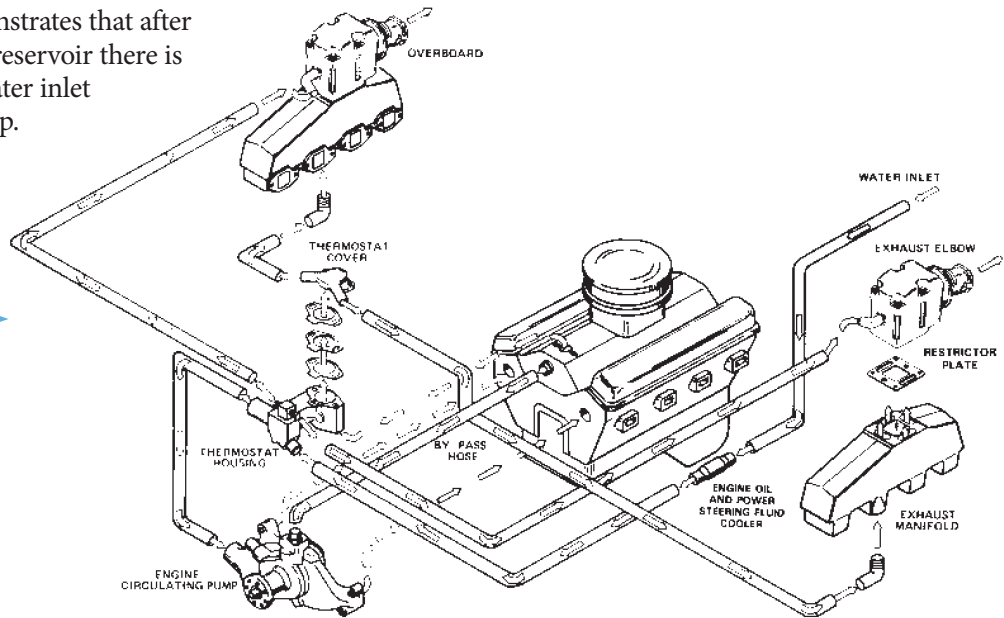

DIAGRAM © WWW.BOATPARTSTORE.COM

## Inboard Engines

An **inboard engine** is a marine propulsion system enclosed within the hull of the boat. Inboard engines have a raw water cooling system where water from the reservoir is pumped by the engine to cool it.

Attached to the hull of the boat is the propeller shaft and propeller which propels the boat through the water. The rudder acts as the “steering wheel” to guide the boat.

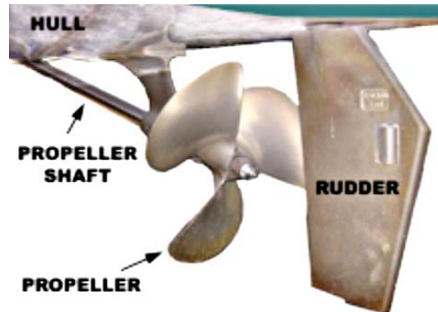

DIAGRAM © BOATCOURSE.COM

After opening the inboard engine compartment, the bilge area around the engine can be inspected and/or decontaminated for standing water.



PHOTO © GLASTRON



## Closed Cooling System Water Flow

(Closed Cooled Models)—This diagram shows how water from the reservoir/lake is circulated throughout the engine. As with the I/O, when the boat is exiting the water body, water is left in this system and is expelled into the next water body.

- |                              |                                     |
|------------------------------|-------------------------------------|
| a Exhaust Elbow              | i Check Valve                       |
| b Exhaust Manifold           | j Power Steering Cooler             |
| c Water Pump                 | k Flush Fitting (Inboard Models)    |
| d Heat Exchanger             | l Flush Connection (Inboard Models) |
| e Water Circulating Pump     | m Shaft Log Seal Connection Point   |
| f Thermostat Housing         |                                     |
| g Water Distribution Housing |                                     |
| h Cool Fuel Box              |                                     |

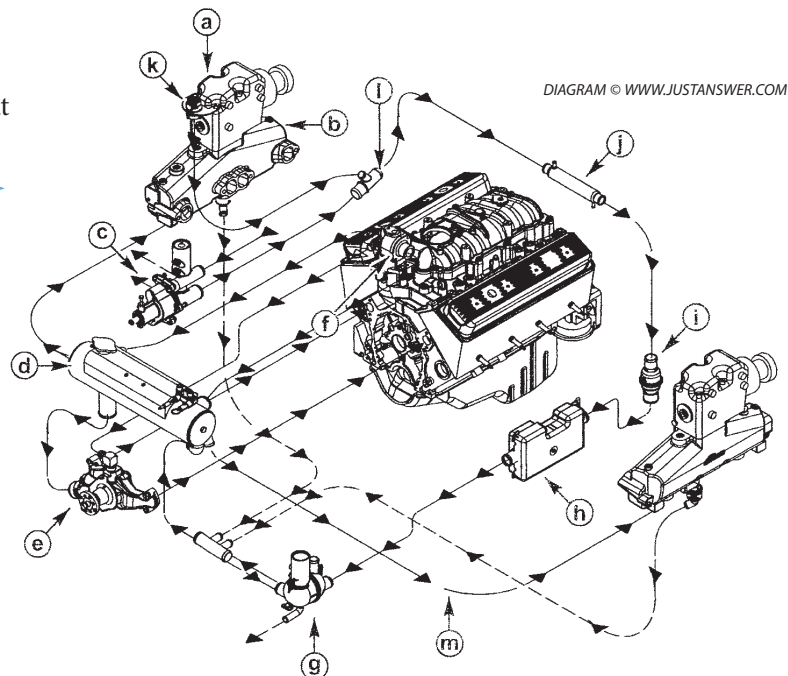

77928

# Alumacraft

Alumacraft has been manufacturing aluminum, outboard driven boats since 1946. They focus on fishing boats from 10 feet to 20 feet 8 inches and have many different styles of boats ranging from the simple...

...to the complex.



PHOTOS AND DIAGRAMS © ALUMACRAFT

The **Trophy** fishing boat models are featured in their Sport and Fish boat series. They have live wells, bait wells, numerous storage areas, and a bilge area with a bilge pump.

Another model of the Sport and Fish boat series is the **Tournament Sport** boats. These have larger sized live wells (12 to 30 gallons) that must be thoroughly drained prior to the boat leaving the reservoir.

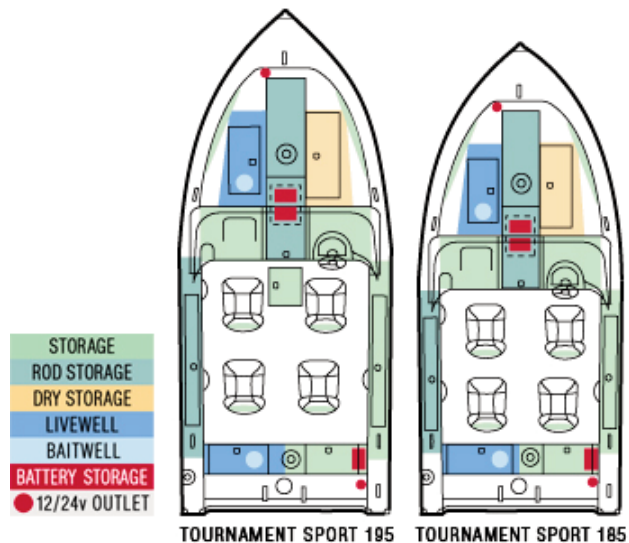
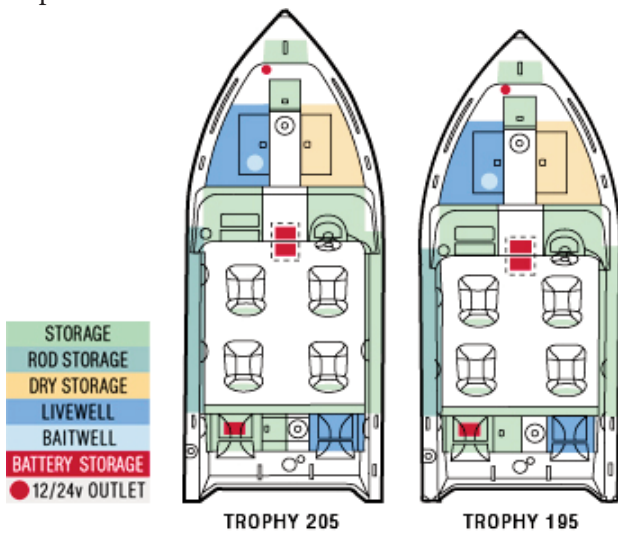

The riveted **Jon** boat series has numerous models; some are simple boats with no compartments and a single outboard motor, while others have storage compartments or a live well.

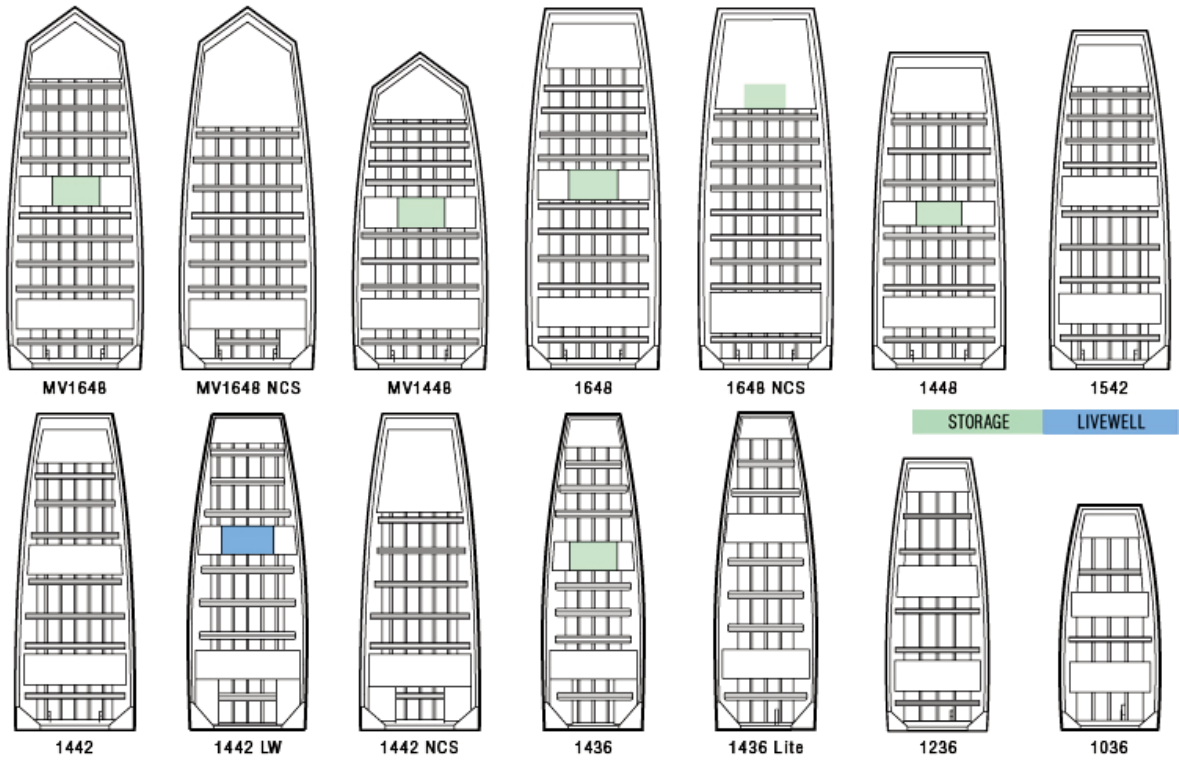

All of the welded, side console **Jon** boat series have live wells, numerous storage compartments and bilge pumps.

DIAGRAMS © ALUMACRAFT

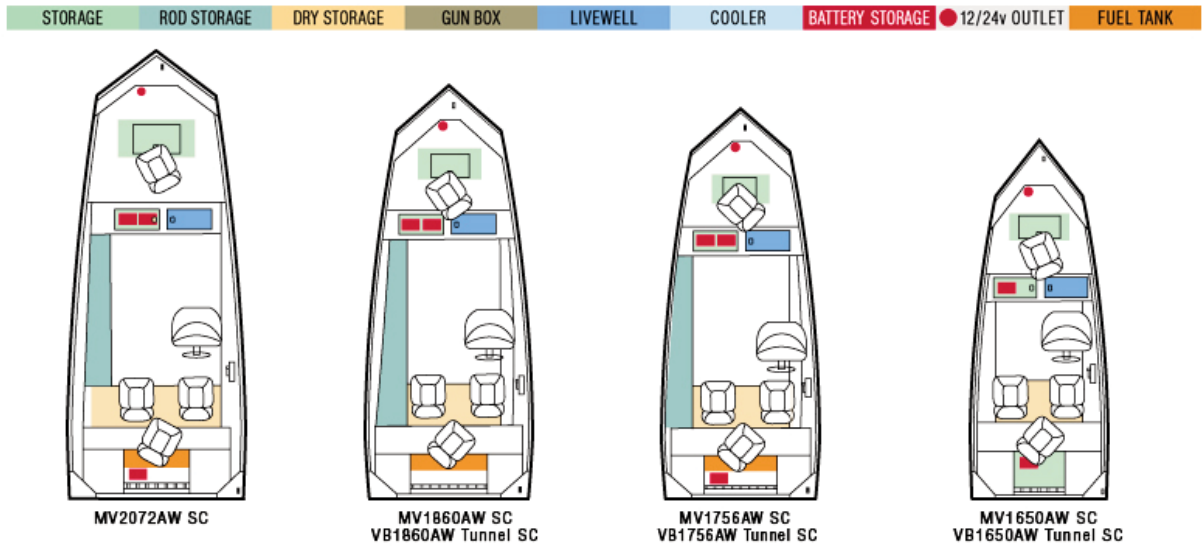

# Bayliner

## Most Popular Models:

Runabouts, Cuddys, Deck Boats, Cruisers, Bowriders

Bayliner boats have been manufactured for over 50 years. They have too many models and types to publish. Our goal is to focus on the most popular models and the specific areas that a boat inspector should be aware of in order to complete an inspection and decontamination.

When inspecting the exterior hull of a boat such as the Bayliner Cruiser series, the inspector may not be familiar with many of the items. This is when it is important to ask the boat owner questions about those items so that the inspector is doing a complete inspection and ensures a safe and effective decontamination.



## Hull Views

DIAGRAM © BAYLINER

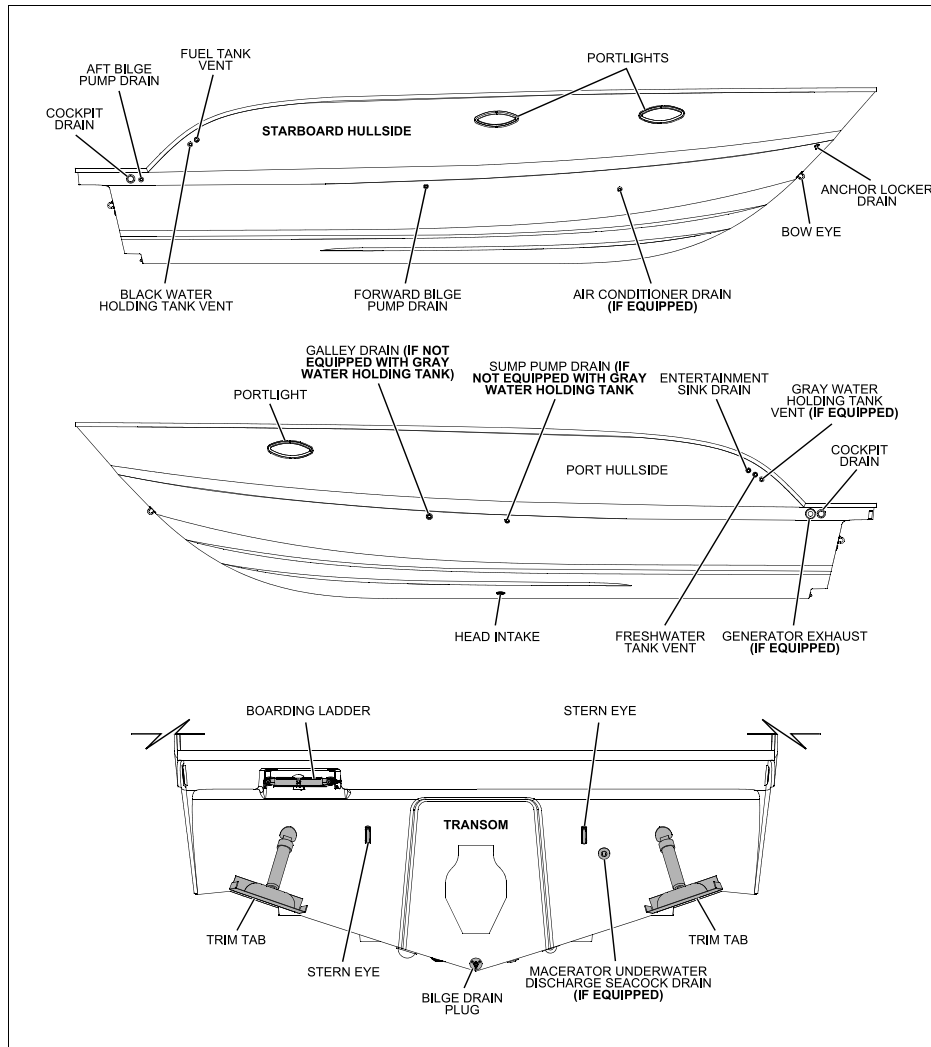

All models have storage compartments which could hold an anchor or equipment such as skis, life jackets and other water toys that could have come in contact with the water body. Some have under-seat storage, cockpit floor storage, bow storage compartments (some dedicated and others hidden behind the backrests) and cockpit deep in-deck storage lockers.



Many of the swim ladders have a hide-away cover and can be located either in the front or back areas of the boat.



A few of the models have aerated live wells. Examples of this may be found on the **185 Ski N Fish**, the **Bowriders 195 Discovery**, the **Cuddy 192 Discovery**, and the **Cruiser 266 Discovery**.

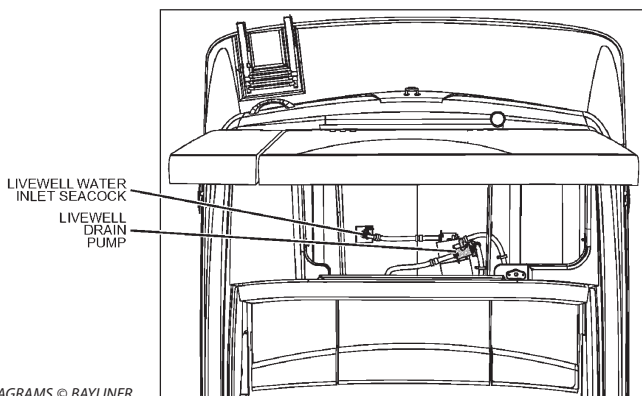

DIAGRAMS © BAYLINER

The **Cruiser Discovery** model has an underseat live well option which is quite hidden; this live well (see diagram below) is located under a seat cushion. The inspector needs to ask the boater if they have a live well so that this very important compartment is inspected. **Never assume that a boat does not have a live well.**

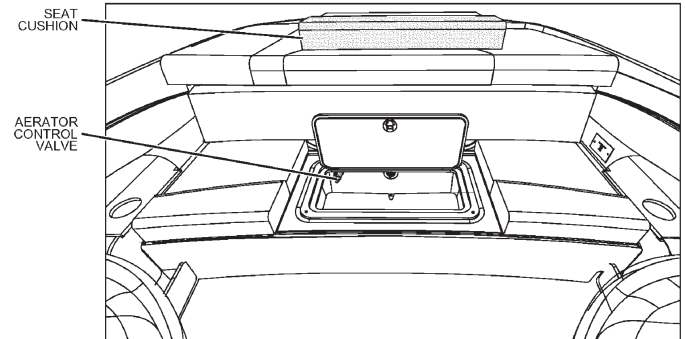

**Live Well Aerator Control Valve (185, 195 & 205 Only) (If Equipped)**

- Located inside the live well.
- To Access: Remove the center bench seat cushion, lift the live well hatch.

The Cruiser models are very complex having numerous storage compartments and sinks.



The Bayliner models that are equipped with an inboard/outboard have a bilge pump in the engine compartment. If the inspector can identify the pump's manufacturer, then they should adjust the decontamination unit's temperature accordingly.

This photo shows a Johnson pump that is temperature rated at 170°F.

Please note how it is lifted off the bottom of the interior hull. Water will still be present after this pump has been activated and no more water exits through the through-hull drain.



**Live Well Drain Pump & Water Inlet Seacock (185, 195 & 205 Only) (If Equipped)**

- Located in the forward area of the engine compartment.
- To Access: Lift the motor-box cover.

The Cruiser boat series has two bilge pumps with their corresponding through-hull discharge drain. Each of these pumps will need to be activated during inspection and decontamination. During decontamination this diagram emphasizes the need to first run the low pressure hot water into the through-hull drain fittings due to the length of the hoses between the pumps and the exterior of the hull.

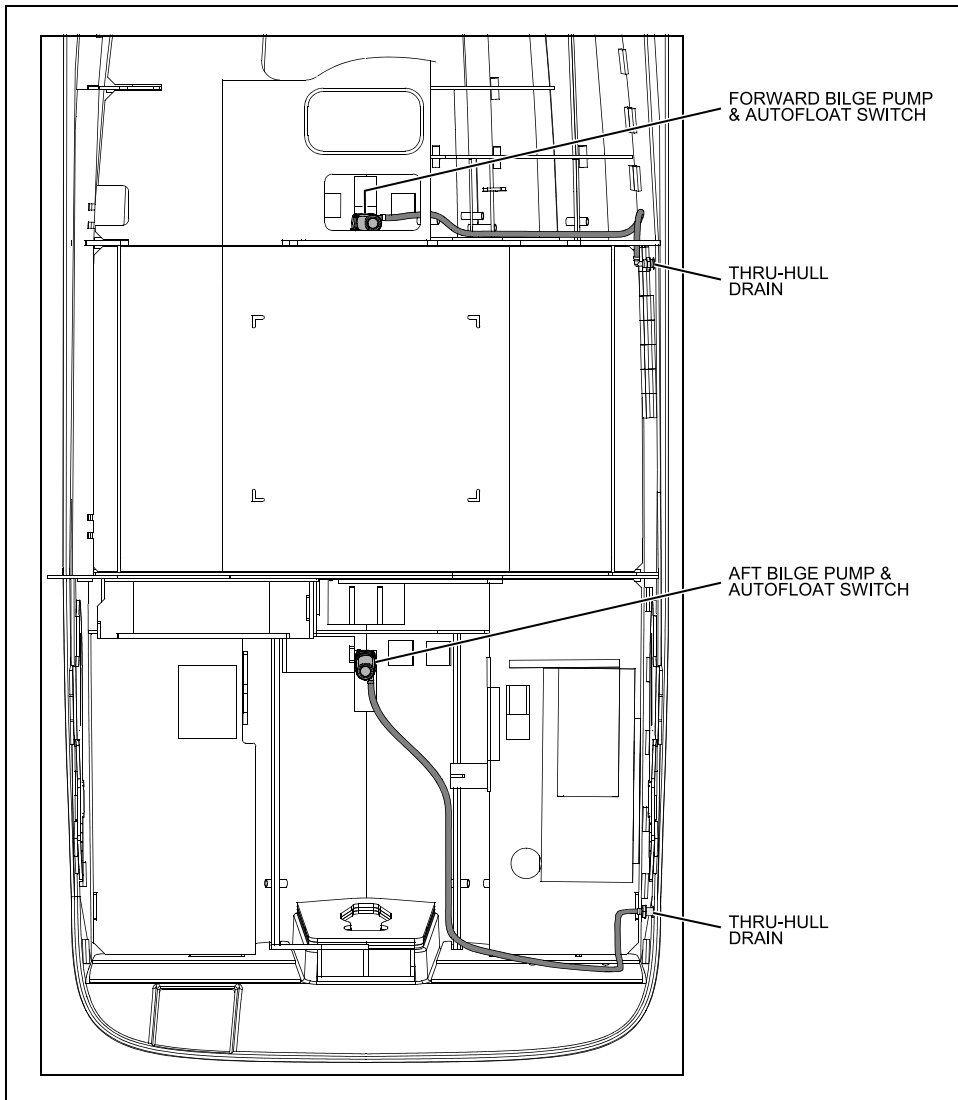
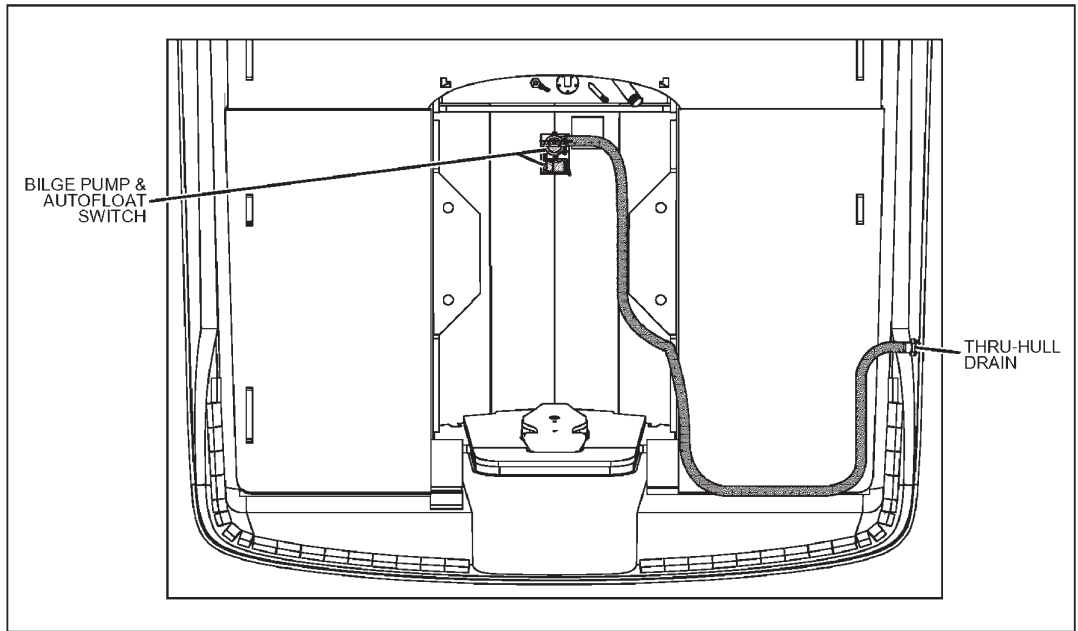

DIAGRAMS © BAYLINER



# Chris-Craft

Chris-Craft has manufactured boats for over 130 years. They have numerous models and series that include: Runabouts, Cuddy Cabins, Bowriders, and Express Cruisers. They have a line of center console fishing boats that are very complex.



## Catalina Fish Boat Series

These boats may have in the helm seat module a 28 gallon live well/bait well, two fish boxes on both the port and starboard sides with a macerator pump. Fish boxes are typically mounted into the floor of the vessel and are very often below the waterline or only partially above the waterline.



The macerator pump is the ideal pump for the emptying of a fish box and live well receptacles due to its self-priming capabilities and its grinding properties. Typically, on this series, there are forward and aft bilge pumps with corresponding discharge through-hull drain fittings, a ladder storage area, and a raw water wash down outlet at the port entry.



There are numerous storage areas underneath the bow seating area. Inspectors must ask the boater to remove the cushions to access and inspect the numerous storage areas underneath.



PHOTOS © CHRIS-CRAFT

# Fisher

The **Fisher** lineup includes a full range of **Mod V** fishing boats, **Deep V** fishing and **Sport** boats, plus **Jon** and utility boats. The Jon and utility boats include options which have basic unpowered boats with only bench seats in their interior.



However, a number of their models do have bow and aft aerated live wells with bait well inserts, rod storage and equipment storage compartments.

As with other manufacturers, the differences between the models include size, equipment, and seating arrangement.



PHOTOS AND DIAGRAMS © TRACKER MARINE GROUP

# Four Winns

PHOTOS © FOUR WINNS



The **Four Winns** boat manufacturer has five series which include the **H, SS, SL, F,** and **V Series**. Within these series there are numerous models that differ in size and the equipment that is offered.

All of these series boats have interior compartments which makes them “complex” boats when determining risk factors. Typically they have anchor storage beneath the bow seat, a storage compartment for the aft ladder, and an in-floor ski locker with a rubber mesh or carpet liner.



For the models that have an inboard or inboard/outboard engine there is an engine compartment that must be inspected for standing water.



The engine motor compartment is located in the rear of the boat.

# Glastron

The **Glastron** boat manufacturing company has been building fiberglass boats since 1956. They make **Bowriders**, **Ski & Fish**, **Deck** boats, and **Cabin** models.



All models have bilge pumps, ample storage areas, ladder, and anchor storage compartments.



Many have the option of adding aerated live wells.



PHOTOS © GLASTRON

# Grenada Ballast Tank Sailboats

**Grenada** sailboats utilize water ballast which allow the sailboat to be very light for trailering but heavy enough for safe sailing.

Water ballast is carried in the hull as well as the keels, which allows the keels to be thinner, resulting in reduced drag at high speed. The water ballast system is very simple, one valve for each keel. Open the valve and the keel fills (or drains if you're out of the water). Close the valve and the water is captured. If you want more performance, especially in light conditions, pumps may be added to transfer ballast. Each keel contains roughly 20 gallons of water.

In this photo, the sailboat on the left is un-ballasted. However, the one on the right is an example of a twin keel ballast sailboat and the water intake and drainage is the same as the **Grenada 14**.



## Grenada 14

- 14 ft. LOA
- 66 in. Beam
- 18 in. Draft
- 110 sq. ft. Sail Area
- 1,150 lbs. Loaded Displacement
- 350 lbs. Water Ballast
- 250 lbs. Dry Weight

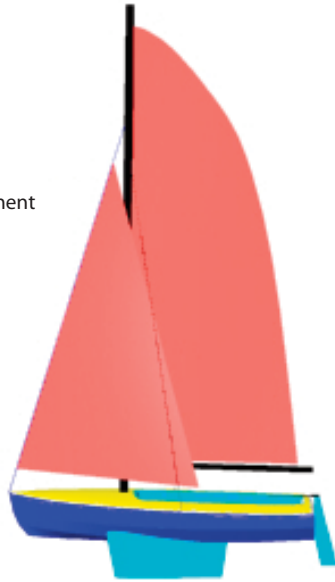

**Internal and Water Ballast**—The ballast within a sailboat is the weight that pulls the boat upright after a knock down. The lower you can get the weight, the better a chance the boat has of righting itself after a knock down. Some designs have the ballast attached inside the hull in the bilges in the form of concrete and iron, custom molded lead weights, or **water tanks**. This form of ballast works, but isn't as effective as an externally held ballast. In the case of **water ballast**, you fill the tanks when launching your boat and drain them when retrieving it back onto the trailer, so you don't have to pull all that weight on the road.

Water ballast sailboats are becoming popular in part due to their low trailer weight. With the water drained, these boats can be pulled by a small car, and are one solution to high slip fees. Trailering also opens up vast cruising area, from the Pacific Northwest, Florida and the Bahamas, Chesapeake Bay, and the Great Lakes. All just a "freeway away" and Colorado is right in the middle!

The **Grenada 24** combines the advantages of twin bilge keels and water ballast. The boat can be beached safely, gains stability by placing the water ballast low in the twin keels, and is light enough to be trailered.

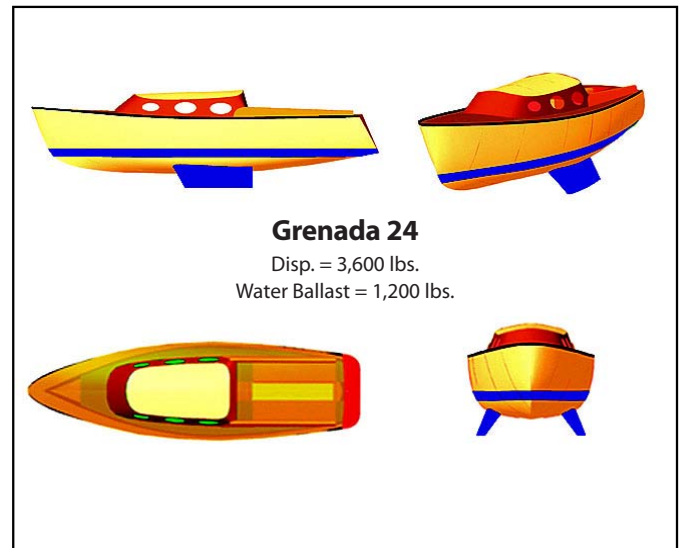

# Hobie Cat Sailboats

PHOTO © HOBIE CAT

Hobie Cat manufactures two types of sailboats: Rotomolded sailboats with models that include the **Bravo**, **Wave**, and **Getaway**; and Fiberglass sailboats with models that include the **Hobie 16**, **FX One**, and **Wild Cat**. All of these models are simple to inspect. However the plugs on the back end of the catamarans must be open during the inspection, the rudders clean, and all ropes and equipment must be dry.



PHOTO © HOBIE CAT



PHOTO © HOBIE CAT

Open plugs on back end of catamarans.



Many trailers are tubular and therefore must be inspected and/or decontaminated thoroughly.



# Jetcraft

Since 1996, **Jetcraft** has been manufacturing fully welded, heavy gauge aluminum boats. They have two series that may be found in Colorado, the **Outboard** and **Jet** Series.

All of the models in both series have bow and anchor storage areas. All of the models in the Outboard Series have bilge pumps and transom wells. The three models of the Outboard Series that have a transom fish locker are the **2025 Discovery**, **2225 Discovery**, and the **2425 Discovery**.



A **jet boat** is a boat propelled by a jet of water ejected from the back of the craft. Unlike a powerboat or motorboat that uses a propeller in the water below or behind the boat, a jet boat draws the water from under the boat into a pump inside the boat. The water then passes through a series of impellers and stators—known as stages—which increase the velocity of the water flow. The water is then expelled through a nozzle at the stern. Most modern jets are single stage while older waterjets may have as many as three stages. The tail section of the waterjet unit extends out through the transom of the hull above the waterline. This jet stream exits through a small nozzle at high velocity to push the boat forward.

When inspecting or decontaminating a jet boat, the boat inspector must locate the intake port on the bottom of the hull. Also, as with a PWC, inboard, or inboard/outboard engine, the engine compartment must be inspected/decontaminated.



BOAT PHOTOS © WESTWINN GROUP CORP.

# Kenner

Kenner boat manufactures two different Series, the **VX** and **Vision** series. The models in the VX Series include: **180 VX**, **180 VX Tunnel**, **19 VX**, and **19VX Tunnel**. The models in the Vision Series include: **1800**, **1800 Tunnel**, **1860**, **1902**, **1902 Tunnel**, **2103**, and **2103 Tunnel**. Their focus is primarily fishing boats. They provide the boat owner with numerous equipment options.

- Aft live well w/recirculator
- Aft live well w/Max-Air™ induction system
- Fish O2™ oxygen generator
- Aft live well w/Pro-Air System and recirculator
- Aft live well w/Pro-Air System
- High-speed freshwater pickup

It is important to inspect these systems and to take extra precautions when performing decontamination as to not damage any of the equipment.

The Vision Series has numerous storage areas, a transom well and live well areas.



PHOTOS © TRACKER MARINE GROUP





# Lund

Lund boats are widely used by Colorado fishermen. They manufacture six different series of styles, which include: the **Rebel Series**, **Sportsman Series**, **Tournament Series**, **Sport & Fish Series**, **Jon Boat Series**, and the **Wilderness Series**. Each series has a unique style and placement of the storage compartments, live wells, bait well, and bilge area.

All Lund boats, except for some of the Wilderness Series and Jon Boat Series, have a bilge pump and a live well with a possible attached bait well.

Following are diagrams of some of the series models. The **storage compartments** are colored **green**, the **live wells** are colored **blue**, and the **bait well** is colored **orange**. **Yellow** indicates **seating** and the **fuel tank** is colored **pink**.



## Jon Boat

The Jon Boat models are #1436L, #1236, #1232, and #1032. These would be classified as a simple boat (an open hull design with no interior compartments).

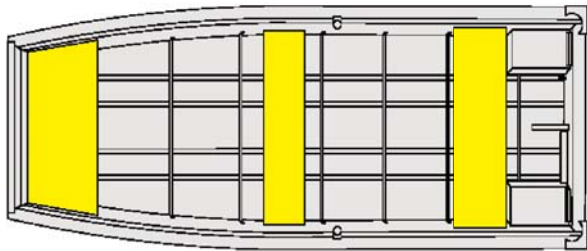

Other models of the Jon Boat series have a small live well (in blue) and a storage compartment (in green) in the center of the boat.

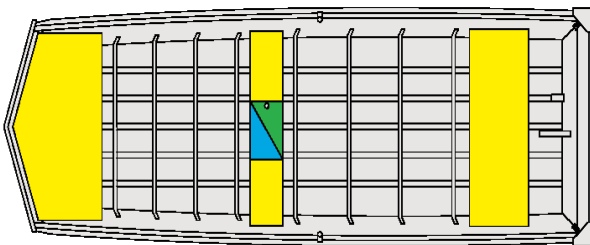

DIAGRAMS © LUND

## Wilderness

The Wilderness Series models that would be categorized as a simple boat are: WC-#12, #14 and #16; the SSV-#14, #16, and #18; the A-#12 and #14; and the WD-#14. Below is an example for that Series.

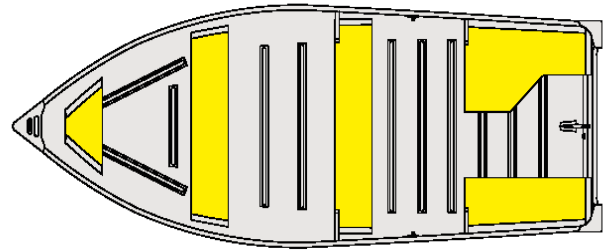

The more complex boats in the Wilderness Series either have a live well located in the forward area of the boat or a live well with a bait well located on the port side of the boat. An example of a live well (in blue) and the bait well (in orange) are seen in the diagram of the 1600 Alaskan SS model below.

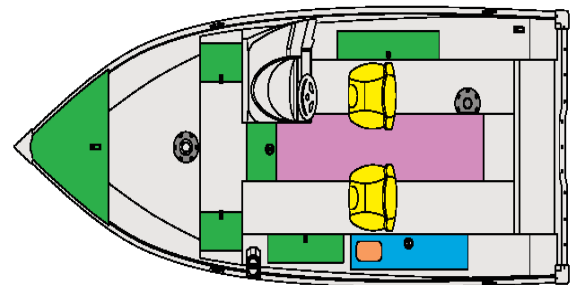

### Sport & Fish

In the Sport & Fish Series, there are four models, the 2150 Baron, 1950 Tyee, 1850 Tyee and the 1750 Tyee. These all have two live wells located in the forward starboard side and in the rear of the boat. The **2140 Baron** and the **1950 Tyee** both have a bait well in the rear live well area. They also have two high-capacity bilge pumps. Below is a diagram of the **1750 Tyee** with the two live wells (in blue), and numerous storage compartments (in green).

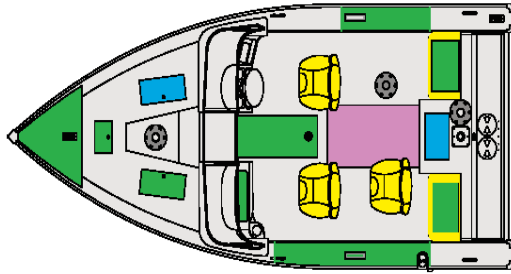

### Sportsman

The focus on the Sportsman Series models is big decks, big storage and big capacity live wells. Most of the models will have two live wells, one aft and one bow, with many having an 18 gallon capacity and a bait well. Depending on the model, they usually have a one manual bilge or one manual/auto bilge. The two models of the **Sport Angler**, **1800** and **2000**, may have a wash basin as optional equipment. This area needs to be inspected and possibly flushed during the decontamination process.

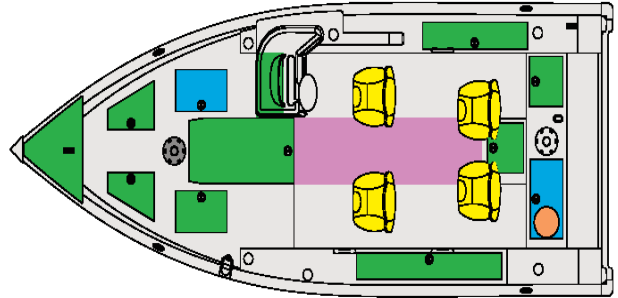

### Tournament

The Tournament Series models have a huge bow casting platform which doubles as extensive storage. They have an aft bait well, a 27.5 gallon aft live well and a 10 gallon bow live well on the starboard side. They also have two high-capacity bilge pumps. These models are very complex and added time is needed in order to complete an inspection.

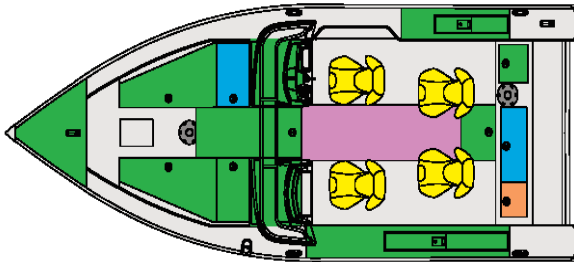

### Rebel

The Rebel Series models are known for their live well systems and numerous storage compartments. All models have one manual bilge pump. The XL models have a 20 gallon aerated live well with a bait well. All other models have an aerated 10 gallon live well.

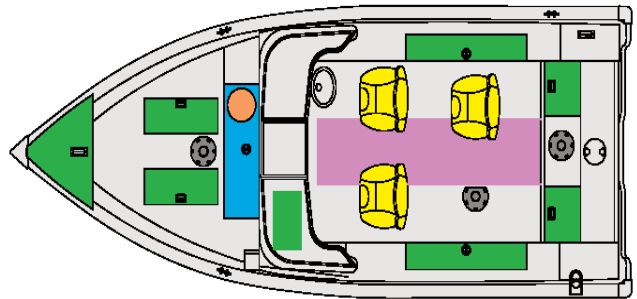

DIAGRAMS © LUND

On the next page, there is a diagram of the three live well models that are featured on Lund boats. They all have plugs and pumps.

## Examples of Live Well and Aerator Pump Diagrams

Below are some examples of live/bait wells from the Lund Boat Company. This section is intended to provide inspectors and decontaminators additional information regarding the complexities of wells.

Only low pressure and 120°F water can be used when decontaminating a live/bait well to ensure no damage is done to any of the numerous parts.

The numbers on the following list refer to individual parts shown in all three diagrams.

- |                                |  |
|--------------------------------|--|
| 1—Removable divider            | 9—Max-Air intake                             |
| 2—Baitwell drain               | 10—Recirculating outlet                      |
| 3—Fill spray head              | 11—Recirculating pump with filtration screen |
| 4—Overflow                     | 12—Aerator pump with filtration screen       |
| 5—Freshwater pickup            | 13—Through-hull drain                        |
| 6—Waterproof light             | 14—Drain with plug head                      |
| 7—Freshwater pickup spray head |  |
| 8—Recirculating spray head     |  |

The **ProLong Plus** is designed with a freshwater pickup integrated into the bottom of the hull where it forces a steady flow of water into the live well while the boat is running.

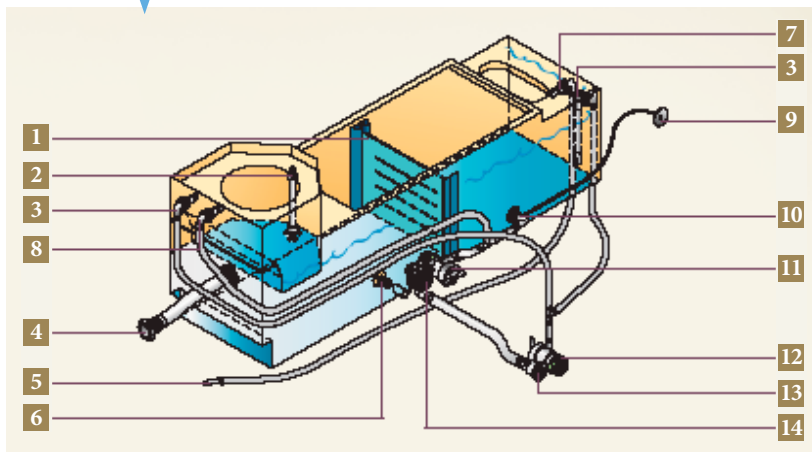

DIAGRAMS © LUND BOAT COMPANY AND CRESTLINER BOAT COMPANY

This is a **two-pump design**. One pump fills and aerates the well from above the fish while the other recirculates and injects fresh air via the Max-Air system for the oxygenation.

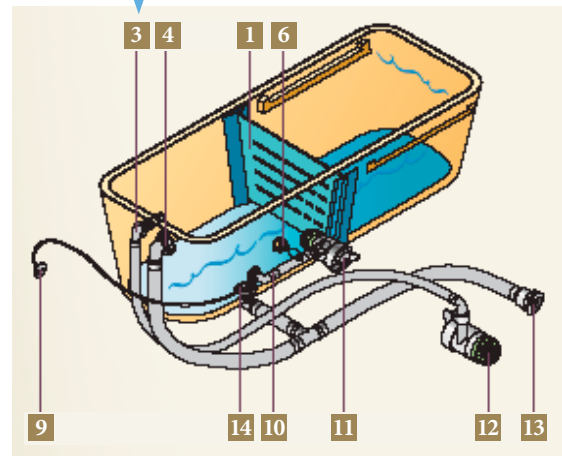

This live well features a **single pump** with a single-switch control. The aerator pump can be run continuously in manual mode or intermittently in automatic mode when equipped with a timer.

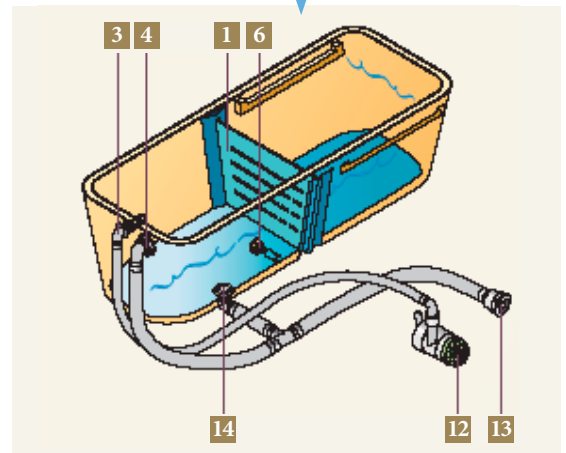

When decontaminating a live well and possibly a bait well, make sure that you use low pressure and turn your decontamination unit's temperature down to 120°F. Make sure that the live well pump and aerator pump are activated during the decontamination process to ensure that the pumps and the connecting hoses have been decontaminated.

# MacGregor Sailboats

MacGregor sailboats utilize water ballast which allow the sailboat to be very lightweight for powering and trailering, and also have the heavy stability necessary for safe sailing.

After launching, the transom valve is opened and a tank in the bottom of the hull is gravity filled with 1,150 lbs. of sea water. It takes about five minutes to fill. The valve is then closed, trapping the water. Under power or sail, the ballast makes the boat stable and self righting. When the boat is floated back onto its trailer, the valve is opened. The car and trailer start up the ramp and gravity drains water out of the boat, resulting in a trailering package that is lighter than most small powerboats. You can also empty the tank while the boat is in the water. Under power, at about six mph, open the valve on the transom and the tank will drain in about five minutes.

The daggerboard trunk (shown below) is lowered during launch and retracted when the sailboat is in shallow water or being trailered. This area can't be decontaminated from the top and there is limited space from below to perform a decontamination with a trailer cross member in the way.

DIAGRAM © BY CINDY BRADY, CPW ANS PROGRAM

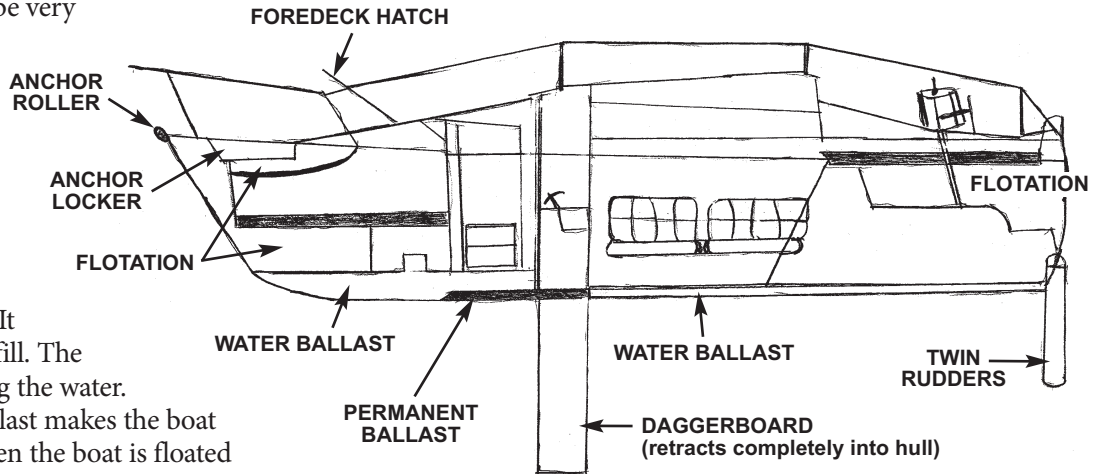

The diagram above represents a schematic of the MacGregor sailboat and its complexities.

A **daggerboard** is a retractable keel used by various sailing craft. While other types of centerboard may pivot to retract, a daggerboard slides in a casing. The shape of the daggerboard converts the forward motion into a windward lift, countering the leeward push of the sail.

Daggerboards are often long and thin, thus providing a better lift-to-drag ratio. Daggerboards are usually found in small craft such as day sailors, where their size is easily handled by a single person. When a daggerboard is extended through the keel, it improves a ship's stability. Daggerboards can be raised when a ship enters a shallow harbor, allowing the boat (for example) to load and unload cargo in locations that would not otherwise be accessible to larger ships.

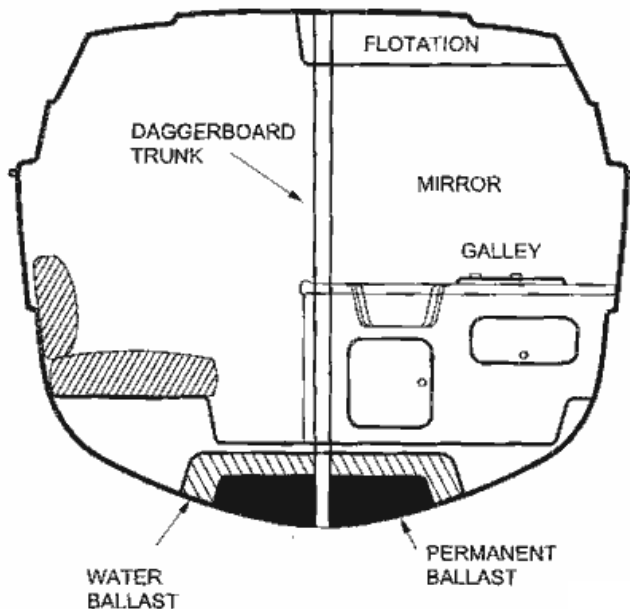

DIAGRAM © MACGREGOR

*Note: One gallon of water weighs about 8.34 lbs. at room temperature, but the weight varies with the temperature.*



# MasterCraft

MasterCraft has been manufacturing boats since 1968. Their focus is in building ski, wakeboard, and luxury performance powerboats. MasterCraft has numerous models that include: the **V, X, Prostar, Maristar, CSX**, and the **300**.

## V model

The V model has the **200V, 215V, 225V, 235V, 245V, 255V, and 280V**. This model has many storage/equipment compartments located in the bow and at the rear of the boat under the expansive sun pad. Many have a compartment for the ladder and anchor located in the bow of the boat.

- The 200V and 215V have I/O engines and bilges with pumps.
- The 225V (comes standard with ballast tanks), 235V, 245V, and 255V come equipped with an inboard engine.
- The 280V has twin inboard engines.

## X model

The X model has the **X-1, X-2, X-7, X-14, X-14V, X-15, X-25, X-30, X-35, X-45, X-55, X-80** and the **X-Star**. These are all complex boats with storage areas, a center drain plug in the floor compartment, bilges, I/O engines and inboard engines.

- The X-1 and X-14V can be ordered with either two or three ballast tanks.
- The X-7 and X-14 have the MTS Ballast System with port, starboard, and rear ballast tanks possible.
- The X-25 and X-30 have three ballast tanks, two in the back and one forward.
- The X-2, X-15, X-35, X-45, and X-55 have one ballast tank located under the floor board in the front of the boat. These also have an anchor/ladder storage compartment on the bow of the boat, and forward and aft bilge pumps.
- The X-80 and X-Star have three ballast tanks and twin inboard engines.



PHOTOS © MASTERCRAFT UK

### Prostar

The Prostar model has the **190, 197, 214, and 214V**.

- All Prostar boats have the MTS Ballast System with the option of having a port, starboard, and rear ballast tanks. ➡
- Prostar 190 and 197 have two ballast tanks standard.
- Prostar 214 has three ballast tanks standard.
- They have a bilge through-hull drain fitting on the starboard side.
- There is a center drain plug located in the floor compartment.
- Most of the Prostar boats have a shower wand attachment at the starboard aft.



### Maristar

The Maristar has the **200, 215, 230, 235, 245, 255, and 280** boat styles. ➡

- The Maristar 200 and 215 have a ballast tank located beneath the floor board. They also have a forward and aft bilge.
- The Maristar 230 has three ballast tanks, two in the back and one forward, and a forward and aft bilge.
- The Maristar 235, 245, and 255 have one ballast tank located in the front, a forward and aft bilge, and an anchor/ladder compartment on the bow of the boat.
- The Maristar 280 has three ballast tanks and two twin inboard engines.



### CSX

The CSX model has the **220 and 265** boats available. It is the only model that has a fishing package as an option.

- CSX 220 comes with three ballast tanks, forward and aft bilge pumps and an anchor/ladder compartment on the bow.
- CSX 265 has three ballast tanks, three bilge pumps, twin inboard engines and an optional live well. ➡

### Tournament

The Master Craft **300** is the cabin cruiser of the line. It comes with twin inboard engines, anchor/ladder compartment in the bow, a sink and shower, and bilge pumps. The engine compartment is located in the floor of the boat in the aft. There are numerous storage compartments for ski and wakeboarding equipment. ➡



# Maxum

Maxum boat manufacturer has three types of boats: **Sport Boats**, **Sport Cruisers**, and **Sport Yachts**. Each type has numerous models each with unique challenges to a boat inspector.



## Sport Boats

Their sport boats usually come with either an inboard/outboard engine or inboard engine. Within the engine compartment they have a bilge pump

and corresponding discharge through-hull drain fitting on the outside of the hull. They have numerous seating areas with storage under the seat cushions that may hold equipment that has come into contact with the water body. Typically, they have two compartments on either side of the engine compartment that also contain storage areas.

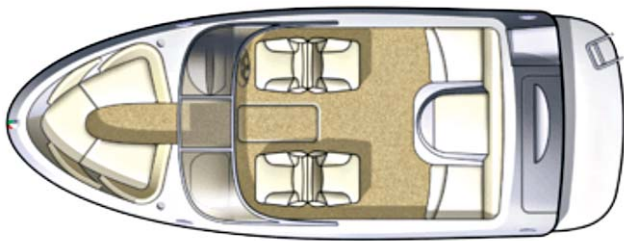

DIAGRAM AND PHOTOS WWW.TOP SPEED.COM

## Sport Cruisers

The cabin cruiser models from Maxum are complex and need to be carefully inspected. Within the engine compartment, they typically have two bilge pumps with their corresponding discharge through-hull drain ports. On deck, there are side storage shelves, storage under seat cushions, and an anchor line hatch and anchor. The transom has, among other items, trim tabs and a transom zinc.



Inside the "cabin" area, they have a head and galley. In the head, they have a sink and shower. In the galley there is also a sink.

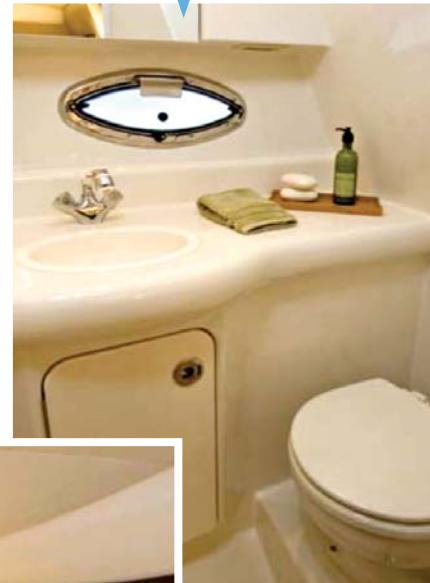



The Sport Cruiser comes with a water holding tank (typically 20+ gallons). The boat inspector must ask the boat operator if tap water is used in these areas or if they are using lake water.

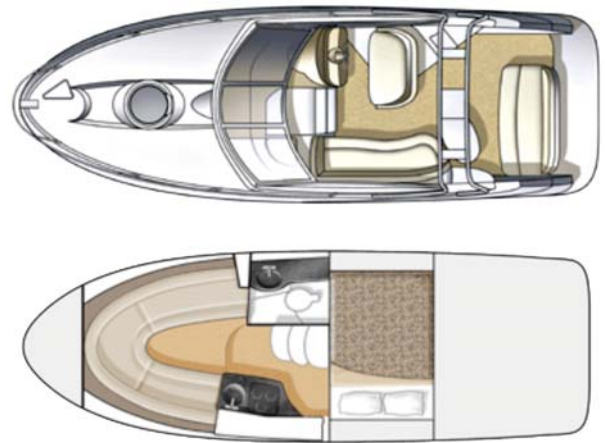

**Sport Yachts**

The length of these yachts, 37+ feet, is typically too large for our reservoirs and lakes. However, it is possible that they can be found at locations such as Horsetooth, Pueblo, or Navajo Reservoirs. They are equally as complex as the cabin cruisers and must be inspected carefully.

- A head with a sink and shower
- An on deck sink
- A galley with a sink

It is important for the boat inspector to find out if the boat operator is using the 30+ gallon water storage tank with tap water or lake water.

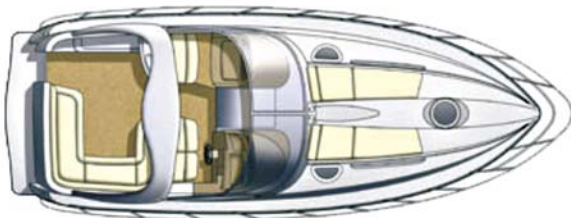

DIAGRAMS AND PHOTOS WWW.TOP SPEED.COM

# Pontoon

There are numerous manufacturers of pontoon boats. They include but are not limited to: **Premier Marine, Manitou, Sun Tracker, South Bay, Starcraft Marine, JC Pontoon, Ponder, Ercoa, Landau, and Lowe.**

A pontoon boat typically floats and balances by means of two large, closed cylinders mounted lengthwise.

Some of those cylinders have vents on the top of the pontoons that release condensation that occurs naturally within the cylinder. Typically, pontoons do not have drain plugs or pumps installed to release this trapped condensation water. Other pontoons have welded seals. Some pontoons have partitions, creating two or more separate internal compartments. **The insides of pontoon tanks cannot be visually checked for mussels or other Aquatic Nuisance Species (ANS).**



Other pontoons have welded seals. Some pontoons have partitions, creating two or more separate internal compartments. **The insides of pontoon tanks cannot be visually checked for mussels or other Aquatic Nuisance Species (ANS).**

- Check pontoons for water by knocking on them. If you hear a dull thud, they could be holding water or be filled with “dock foam”. If you hear a hollow empty sound, the pontoon is most likely dry.
- Listen to pontoons. A sloshing sound when stopping the trailer will indicate trapped water in the pontoon. The inspector must then look for damage, holes or water leaking from the pontoon.

Pontoon boats can be simple to very complex; some have active live wells with pumps.

The live well pump is usually located in a cage-like area at the end of one of the pontoons. Some of the live well pumps are intake only; some can also assist in the drainage of the live well.



When performing an inspection, the trailers for pontoons are usually quite high off the ground providing the inspector good views of the underside of the pontoon and exposure to the trailer. However, as demonstrated by the photos below, there are lots of areas where ANS attachment is possible. During decontamination, the inspector has to be very meticulous and contact every portion with 140°F water and high pressure. Please note the large areas of carpeted bunks. These must be decontaminated by soaking them with 140°F water **at low pressure.**



Pontoons typically have lots of seating with removable seat cushions. During a high risk inspection, the inspector must ask the boat operator to open these areas and inspect the equipment, ropes, and all items that may have come into contact with the water.

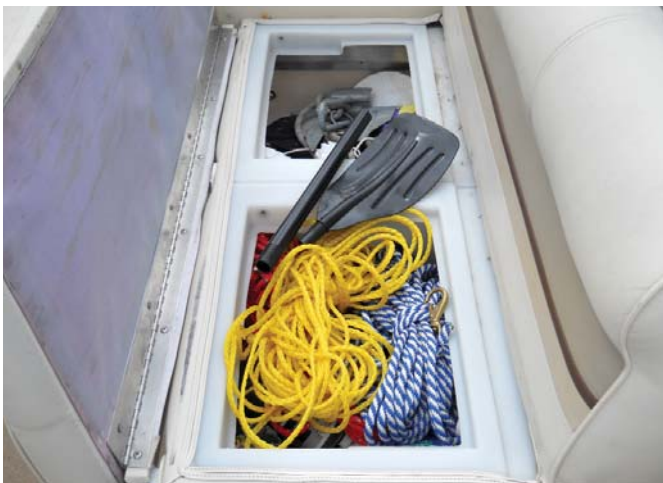

This photo shows a pontoon that has two pumps located in the cage at the back of the pontoon. One pump is for the live well, the other is for a wash station.



One of the best aspects of a pontoon boat for an inspector is that the outboard motor is typically lowered during transport, which means that it should be fully drained when it is inspected.

# Personal Watercraft (PWC)

A **personal watercraft (PWC)** is a recreational watercraft that the rider sits or stands on, rather than inside of, as in a boat. Models have an inboard engine driving a pump jet that has a screw-shaped impeller to create thrust for propulsion and steering. They are often referred to by the brand names **Jet Ski**, **WaveRunner**, or **Sea-Doo**.

Most are designed for two or three people, though four-passenger models exist. Stand-up PWCs were first to see mass production and are popular for single riders.

There are a number of manufacturers that build PWCs. They include, but are not limited to, **Kawasaki**, **Honda**, **Sea-Doo**, **Yamaha**, **Suzuki**, and **DiMora**.

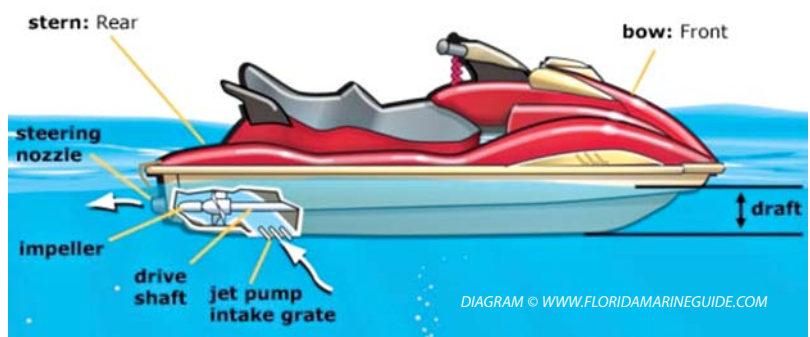

When inspecting a PWC have the operator remove the cover in front of the handle bars and the seat over the motor.



Typically, there are two bilge plugs located on the rear of the PWC on either side of the steering nozzle that must be opened during the entrance and exit inspection.

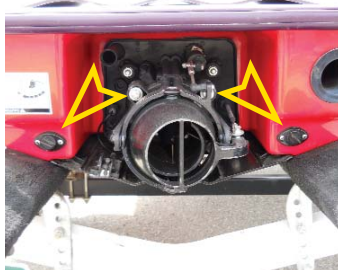

On the bottom of the hull, is an intake grate that must be inspected for mussels, plant, mud, or other suspected ANS attachment.



## How Do I Decontaminate a PWC?

Ask the operator to open the two covers on the PWC. The decontaminator should then start at the bow and perform a standing water decontamination/flush with 120°F water at low pressure in both compartments. Next, back flush the bilge plug openings and the intake grate. Lastly, decontaminate the exterior hull with 140°F water and high pressure, paying special attention to the foot wells. Have the operator run the PWC to blow out excessive water from the decontamination process.

# Ranger

Ranger has been manufacturing boats since 1968. Today they have more than 40 different models within five different series: **Bass**, **VX/VS**, **Fish-N-Play**, **Multi-species**, and **Saltwater**.

## Bass Series

The Bass Series has 12 models available. One of the most popular in this Series is the **Comanche** model.

As shown below, it has a Venturi air and live well pump out system, and numerous storage compartments.



## VX/VS Series

The VX/VS Series is complex in its floor plan. It has numerous storage compartments and a recirculating aerated live well with divider and filter screens.

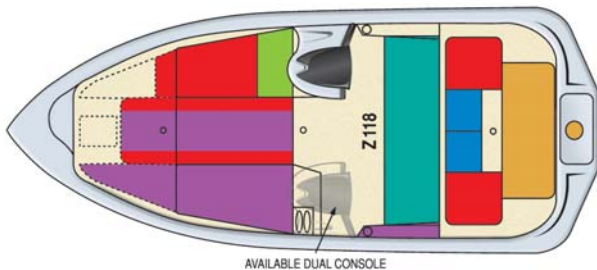

LAYOUT KEY	
Cooler	Green
Bat./Oil/Acc.	Yellow
Storage	Red
Livewell	Blue
Rod Storage	Purple
Fuel	Teal

## Fish-N-Play Series

The Fish-N-Play Series has three models with numerous styles available: **Reata**, **Angler**, and **SS**.

The Reata shown below has larger seat capacity and is complex.



The SS model shown below has two live wells, a bow ladder area, and even more storage compartments.



DIAGRAM AND PHOTOS © RANGER BOATS

# Tracker

The **Tracker** lineup includes a full range of **Mod V** fishing boats, **Deep V** fishing and **Sport** boats, plus **Jon** and **Utility** boats. The **Jon** and **Utility** boats include options which have basic unpowered boats with only bench seats in the interior.



However, a number of their models do have bow and aft aerated live wells with bait well inserts, rod storage and equipment storage compartments.

As with other manufacturers, the differences between the models include size, equipment, and seating arrangement.



PHOTOS AND DIAGRAMS © TRACKER MARINE GROUP

# Trophy Sportfishing

Trophy Sportfishing Boats offer a full line of fishing boats. Models include: **Bay Boats** (19–24 feet), **Center Consoles** (17–22 feet), **Dual Consoles** (22 feet), **Rolled Gunnel Series** (16–18 feet), and **Walkarounds** (18–23 feet).

## Bay Boats

These models have two live wells and some have an insulated fishbox. These must be inspected to make sure they are dry. These models also come with a bilge pump that must be activated to make sure the bilge and its discharge hose are water free.

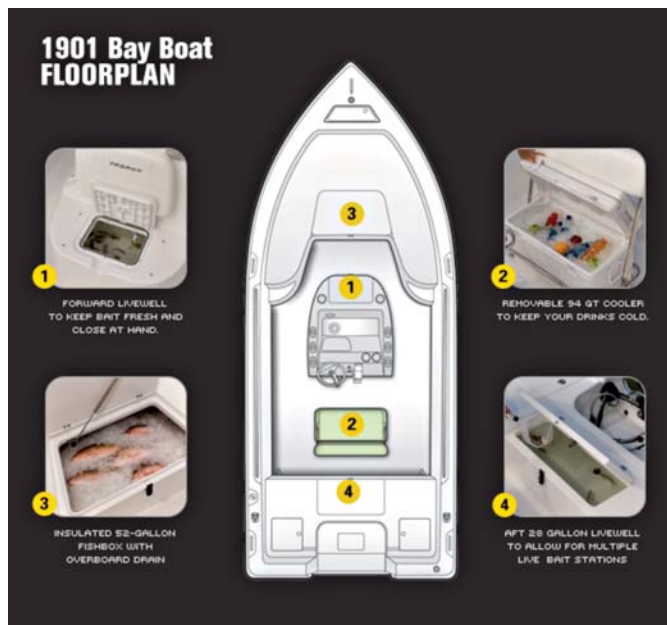

DIAGRAMS AND PHOTO © US MARINE

## Center Console

There are four models of the center console manufactured by Trophy Sportfishing. They include the **1703** which has a 13 gallon live bait well, the **1903** which has a 18 gallon live bait well, the **2203** which has a 35 gallon live bait well and the **2803** which has a 25 gallon live bait well. Each of these models has a bilge pump with an exit through-hull discharge drain port on the aft side of the hull. See the floorplan below for an example of the well placement.

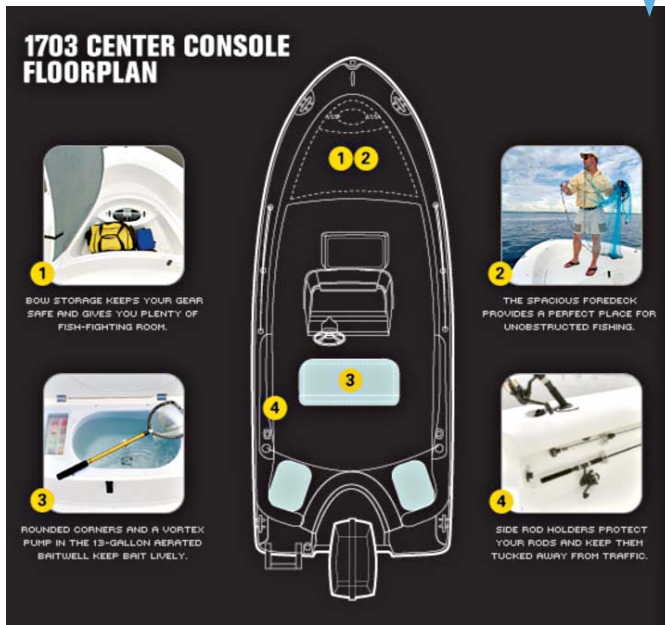

## Rolled Gunnel Series

There are three models in this series: **163 Center Console** which is 16 feet and typically has no live/bait well; **181 Bay Boat** which is 17 feet 17 inches and sometimes has a live/bait well under the center seat cushion; and the complex **183 Center Console** which is 17 feet 17 inches and has a bow storage area, recirculating bait well under the center seat cushion, and two storage areas in the aft port and starboard areas of the boat.

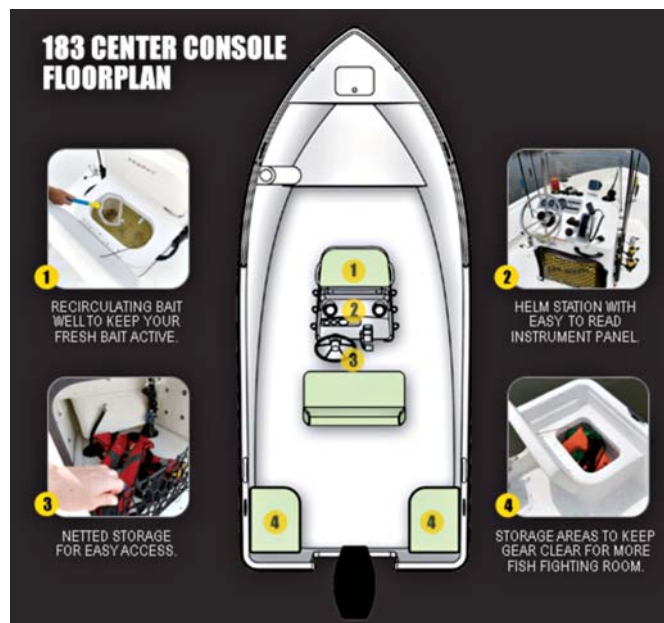

## Dual Consoles

As shown below, the **Dual Console** is a complex boat with fish boxes, a sink with storage area and a 35 gallon aerated live well.



## Walkarounds

These are the “cabin cruisers” of the fishing boat. They can be equipped with 16 to 25 gallon live wells, fish boxes, and raw water deck showers. They are large boats starting at 17 feet 17 inches to over 27 feet.



# Wakeboard Ballast Tanks and Bags

## Ballast Tanks

A ballast tank is a compartment within a boat, ship or other floating structure that holds water.

Ballast water taken into a tank from one body of water and discharged in another body of water can introduce aquatic invasive species. The taking in and dumping of water from ballast tanks has been responsible for the introduction of species that cause environmental and economic damage. The introduction of zebra mussels in the Great Lakes is an example of this damage.

Generally speaking, wakeboard boats are V-drive boats. This means they are an inboard boat with the engine placed backwards in the rear of the boat. This is done to keep more weight in the back of the boat and make the wake larger and steeper. Some wakeboard boat models are direct drive boats where the engine is in the middle of the boat. Most wakeboard boats will have several features that help to create large wakes. These include ballast, wedge, and hull technology.

Most wakeboard boat manufacturers have installed factory ballast but sometimes more weight is needed. Ballast can take the form of hard tanks or soft bags which are filled with water from the body of water the boat is being operated on.

## Ballast Bags

Ballast bags are used to enhance the surf wake made by a wakeboard boat. They are typically filled and drained with a pump connected to a hose. Some ballast bags are designed for integration into an automated ballast system already in place in the wakeboard boat. When filling a ballast bag, it is recommended in most owner manuals to “place the pump in the water keeping it clear of weeds and sand.” When draining, the instructions direct the boater to “place the hose of the pump over the side of the boat.” Because these bags are impossible to fully drain, if a ballast bag has been used in a positive water body, it **must** be decontaminated prior to it being used on any other water, unless it has been out of the water for 30 days or more. Due to the fact that the ballast bags can be integrated into the ballast system of the boat or are filled and drained with the use of a pump, the water temperature of the decontamination unit must be turned down to 120°F to prevent any damage to the pump or bags.

The diagram shows the cross section of a boat with two water ballast tanks. The placement of the tank drain allows water to remain in the tank after the discharge pump has been activated. Manufacturers have reported that on average, two gallons of water remains after draining each tank.

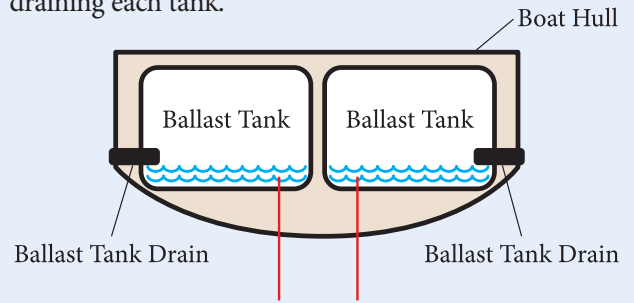

Standing water left in the ballast tank after draining.

**This water can harbor microscopic live zebra and quagga mussel veligers.**

Many of the ballast bags are placed next to the engine in rear compartments, in place of rear seats, in center floor ski lockers, or under the seats of the open bow boats. During an inspection, it is very important for the inspector to inspect all compartments for any equipment that has come into contact with the water.

## Factory Installed Ballast Bags

All **Moomba** ballast boats and all but one model of **Supra** ballast boats have soft ballast bags that have factory installed reversible pumps. They have the same inlet and outlet through-hull drain port located on the bottom of the hull. Almost all of them come with an inboard engine and three ballast bags: two bags are located on the sides of the engine compartment and one in the center floor compartment. All of these bags have a quick connect on the intake and discharge hoses. This way they are easily removed from the compartment to be checked by an inspector. Only one **Supra** model, the **242, 2011+**, has one hard tank located under a ballast bag.

## Other Examples of Ballast Bags

Following are some examples of ballast bags. They can be manufactured in a number of colors and some are uniquely shaped for specific wakeboard boat models.

This custom made **w721** wakeboard ballast bag is designed specifically for the arrow shaped center locker of **Correct Craft Super Air** **Nautique** wakeboard boats.



PHOTO © BAREFOOT INTERNATIONAL & FLY HIGH WAKEBOARDING MFG.



# Acknowledgements

Colorado Parks and Wildlife would like to thank the following companies and persons for their contributions to this compendium. With their help we were able to provide current, accurate information:

Alumacraft  
Barefoot International  
Bass Pro Shops  
Bayliner  
Best Marine Service  
BoatPartStore.com  
Brunswick Worldwide  
Chris-Craft  
Crestliner Boat Company  
Florida Marine Guide  
Four Winns  
Glastron  
Grenada Sailboats  
Harbercraft  
Hobie Cat  
Jetcraft  
John Holtrop's Boat Designs  
Knot-A-Lot Sailing  
Lund  
MacGregor Sailboats  
Malibu  
MasterCraft  
Maxum  
Ranger Boats  
Rocky Mountain Boat Company  
TopSpeed.com  
Tracker Marine Group  
Trophy Sportfishing  
U.S. Marine  
WestWinn Group

Wen Baldwin, Pacific States Marine Fisheries Commission (PSMFC)  
Carly Myers, Service Coordinator, Tommy's Slalom Shop

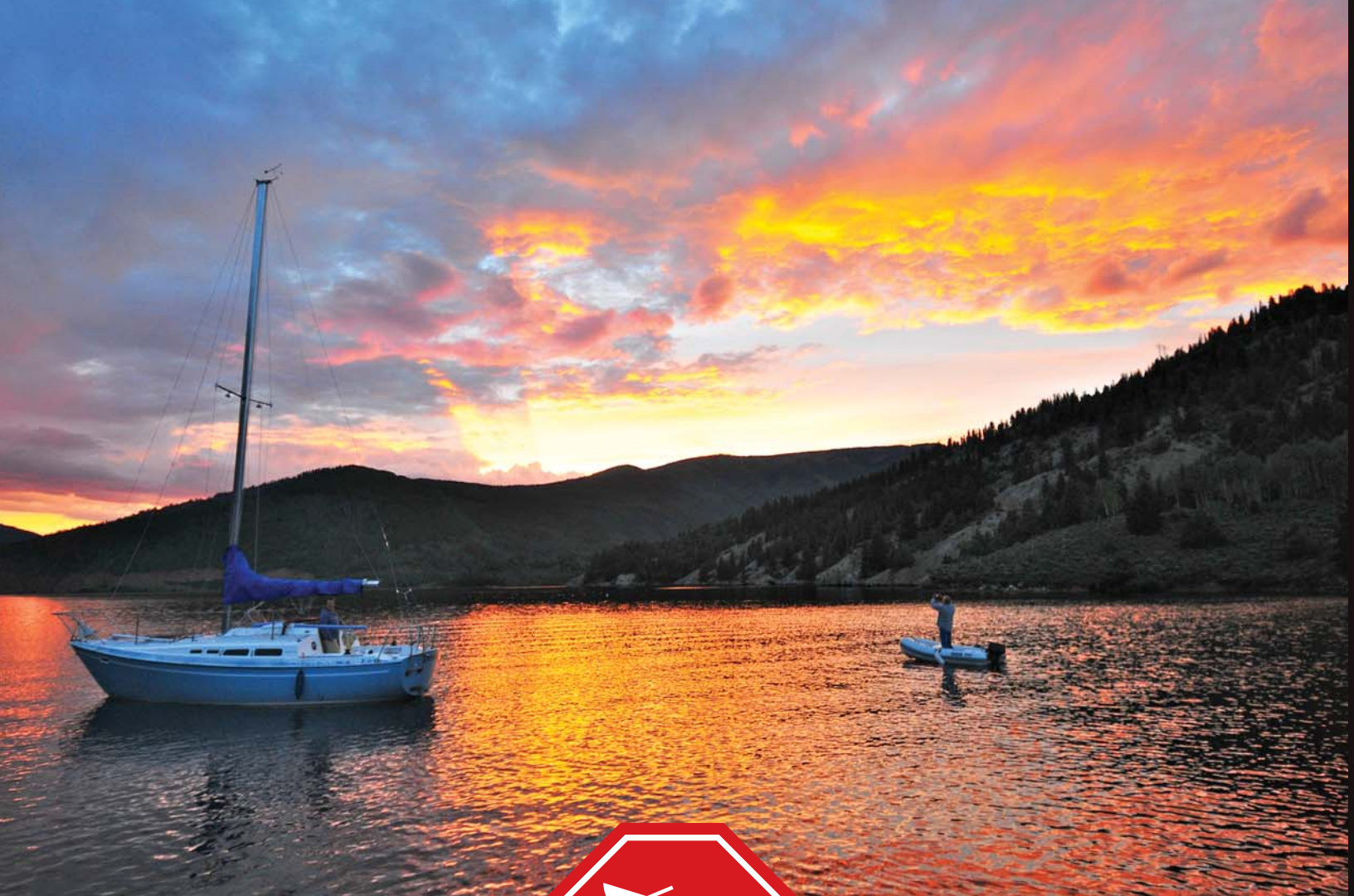

**STOP AQUATIC  
HITCHHIKERS!™**

*ALL PHOTOS © CPW ANS PROGRAM UNLESS OTHERWISE INDICATED*



1/2012 – 1,500